

METHOD OF DETERMINING SIZE DISTRIBUTION OF DROPLETS OF AN ATOMIZED LIQUID

V. F. Dunskaa and N. V. Nikitin

Inzhenerno-Fizicheskii Zhurnal, Vol. 12, No. 2, pp. 254-262, 1967

UDC 536.24.08+66.047.54

It is shown that the devised laboratory method of testing atomizers enables a correct determination not only of the relative, but also of the absolute, values of the parameters of the droplet size distribution.

The efficiency of the atomizers used for the dispersion of liquids in various technical processes depends on the droplet size distribution. The determination of this distribution, however, involves considerable difficulties. These difficulties are due to the need of using fast shutters, which distort the local droplet size distribution [1], the need to determine the average droplet size distribution for the jet of aerosol from the results of local measurements, errors due to possible fractionation of the droplets on impact on the collecting surface, inaccuracies in the conventional microscopic method of counting and measuring the droplets, and so on.

We have devised a stand method of determining the droplet size distribution in atomizer tests. This method, which involves the deposition of the droplets on a collecting surface and the use of a fast shutter, is obviously not free from the distorting effect of the above factors. To assess the over-all effect of these factors, i. e., the degree of reliability and the accuracy of the stand method, we carried out measurements of the droplet size distribution in a standard aerosol not only by this method, but also by two other fundamentally different methods. Below we give a brief description of the methods used and the results of the comparison.

The setup of the stand method is as follows. The frame 1 (Fig. 1) supports a wind tunnel 2 of radius

$R_0 = 375$ mm and with a working region 2400 mm long. A fan 3 mounted on the axis produces an air flow with an average speed of 10 m/sec, which is regulated by means of diaphragm 4. At the rear of the tube and situated vertically along a diameter there is a tube 5 of diameter $D = 12$ mm, which slides freely in guide bushings in the walls. Inside the tube 5 there is a fixed rod 6, the end of which is fixed to an arm 7. In the tube 5 there is a rectangular aperture 8 facing the air flow. The flat working surface of the rod 6, 700 mm long and 5 mm wide, which also faces the flow, is coated with a layer of soot ~ 1 mm thick covered with a thin layer of magnesium oxide.

The investigated atomizer P is mounted at the entrance to the tunnel and produces a jet of aerosol 12, coaxial with the tube. The droplets suspended in this jet are entrained by the air and spread over the cross section of the tunnel. On meeting the tube 5 some of the droplets flow around it with the air and some land on its surface owing to their inertia. When the cock 9 is opened by hand the tube 5, connected to the water cylinder 10, drops under the weight 11 from its extreme upper position to its lower position. The slit 8 exposes the working surface of the rod 6 for a fraction of a second and the investigated droplets land on this surface. They penetrate the layer of magnesium oxide and form round prints on the soot layer. The black prints on the white background can easily be seen and measured under the microscope.

If the process of atomization is steady and symmetrical relative to the tunnel axis the surface count n_i of droplets of the i -th class (i. e., with radius from

Table 1
Experimental Conditions

No. of experiment	Operating conditions		Parameters of liquid				Barometric pressure, kn/m^2	Temperature of ambient air, $^\circ\text{K}$	Method of determining size distribution	Total number of measured droplets
	Rate of rotation of air blower of generator, rpm	Liquid flow rate, kg/min	$\rho_L, \text{g/cm}^3$	$\eta_L \cdot 10^3, \text{nsec/m}$	$\sigma \cdot 10^3, \text{n/m}$	temperature, $^\circ\text{K}$				
1	2250	3.60	1.17	11.0	60	290	98.8	291	Stand	1400
2	2270	3.60	1.17	11.0	60	290	98.8	291	"	1400
3	2250	3.55	1.17	11.0	60	290	99.2	292	"	1400
4	2280	3.55	1.17	11.0	60	290	99.2	292	"	1400
5	2200	3.45	1.17	11.8	61	296	93	299	in closed room	10000
6	2200	3.60	1.17	11.8	61	296	92.5	297	"	10000
7	2200	3.55	1.17	11.8	61	297	93.6	298	"	10000
8	2200	3.50	1.16	11.0	59	296	92.6	296	in field	20000*

*Such a large number of droplets measured in the field experiment is required to smooth out the fluctuations of the aerosol deposits (see [9]).

Table 2
Empirical Droplet Size Distributions

Experiments Nos. 1, 2, 3, 4 (stand measurements)																		
r_i, μ	7	13.5	20.5	27.5	34	40.5	51	65	78.5	92	105.5	119	133	147				
$r_{i\min} - r_{i\max}, \mu$	3.5-10	10-17	17-24	24-31	31-37	37-44	44-58	58-72	72-85	85-99	99-112	112-126	126-140	140-154				
Experiment No. 1	1.00	4.10	9.08	11.1	6.69	5.62	12.1	13.5	8.45	9.35	6.46	1.59	8.57	2.45				
Experiment No. 2	1.80	5.13	9.67	9.57	9.56	5.75	16.9	14.7	8.95	5.30	6.25	4.06	—	2.46				
Experiment No. 3	1.33	3.31	7.10	7.61	6.77	5.13	18.0	14.2	11.2	12.1	8.74	1.08	3.53	—				
Experiment No. 4	0.88	5.80	14.6	16.2	7.25	5.26	11.5	13.8	8.80	5.93	6.03	2.45	1.70	—				
Experiments Nos. 5, 6, 7 (measurements in room)																		
r_i, μ	6.4	12.5	21	29	38	46	54	67	83	108	146	188	230					
$r_{i\min} - r_{i\max}, \mu$	4.2-8.5	8.5-16.5	16.5-25	25-33	33-42	42-50	50-58	58-75	75-91	91-125	125-167	167-209	209-250					
Experiment No. 5	0.54	4.33	8.16	9.22	10.5	12.8	11.5	8.57	14.7	12.3	6.09	0.35	0.02					
Experiment No. 6	0.34	2.64	5.90	8.47	7.91	7.64	9.04	11.7	10.6	17.8	12.7	5.44	—					
Experiment No. 7	0.83	4.52	8.39	12.4	12.9	7.83	6.94	14.6	10.8	12.9	6.49	0.79	0.95					
Experiment No. 8 (measurements in field)																		
r_i, μ	12.5	25	41.5	58.5	75	91.5	108.5	125	141	158	175	191	208	233	267	300	366	
$r_{i\min} - r_{i\max}, \mu$	8.5-16.5	16.5-33	33-50	50-67	67-83	83-100	100-117	117-133	133-150	150-166	166-183	183-200	200-216	216-250	250-284	284-316	316-416	
$g_i, \%$	5.94	19.3	20.1	12.4	15.3	7.04	5.18	3.25	2.76	2.04	2.08	1.04	0.41	2.07	0.25	0.54	0.30	

$r_{i\min}$ to $r_{i\max}$) deposited on the rod 6 is equal to the number of these droplets flowing per second through unit area of the middle cross section of the tube 5 multiplied by the duration of exposure and the capture factor:

$$n_i = u_i(R) c_i(R) \tau \alpha_i.$$

The total number of droplets of the i -th class produced by the atomizer in time τ is found by integration over the cross-sectional area of the tunnel 2:

$$N_i = \frac{2\pi}{\alpha_i} \int_0^{R_0} R n_i(R) dR. \quad (1)$$

The working surface of the exposed rod, which is divided into 14 sections each 50 mm long, is examined under the microscope. A strip of 3×50 mm in each section is examined. On this strip the prints of 100 droplets are counted, measured, and divided into size classes. The area examined is determined by means of the mechanical stage. The rest of the strip is examined for prints of larger droplets. The relative weight of each class of droplets g_i is found from a formula similar to (1). The capture factor $\alpha_i = f(\text{Stk}_i)$ [1], which is contained in this formula and which allows for the incomplete deposition of the droplets on the rod owing to their entrainment by the air flow, is determined approximately from Langmuir and Blodgett's graph for flow around a cylinder ([2], Fig. 46). This graph can be used if the speeds of the droplets and air in front of the cylinder are the same. In our case the speed of the large droplets $u_i(R)$ in front of the tube 5 may greatly exceed the air speed u_a . However, for a stand with the given parameters the value of α_i is much less than unity only for very small droplets ($r_i < 30 \mu$). Calculations of the motion of these droplets (similar to those given in [3], for instance) show that in typical conditions the speed $u_i(R)$ of these droplets in front of the tube is close to the air speed u_a , which is contained in the expression for Stokes criterion. Hence, from this viewpoint the use of the mentioned graph is valid. It should be noted, however, that this graph relates to flow around a stationary cylinder, but in our case the air flows round the moving tube 5, the droplets pass through the aperture in it and land on the fixed inner rod 6; hence the correction introduced by means of this graph is only a first approximation. In the case of a hydraulic atomizer the air speed u_a is approximately constant over the diameter of the tunnel 2 and is equal to the mean air speed in it, i. e., 10 m/sec. In the case of a low-power air-jet atomizer the turbulent jet of aerosol produced by it is propagated within the tunnel 2 in the wake of the air. If the increase in air speed on the axis of the tunnel 2 in front of tube 5 due to this jet is slight (not more than 30%, for instance), it can be neglected in the determination of α_i . In the opposite case we determine the air speed profile in the tunnel and calculate the local values of α_i in accordance with this profile.

The radius R_0 of the tunnel is chosen so that for the given working length and mean air speed of 10 m/sec the largest droplets (with radius up to 200μ) do not

strike the bottom before reaching tube 5. If larger drops are present, the setup has to be altered, by putting the tunnel 2 in a vertical position, for instance.

The settling of the droplets destroys the symmetry of the process to some extent. The effect of settling is reduced by determining the value of n_i as the mean for pairs of rod sections, upper and lower, equidistant from the tunnel axis.

The speed of the tube 5 and the width of the rectangular aperture 8 should be chosen so that the greatest ratio of the total area of the droplet prints to the area of the working surface of the rod 6 is 0.05–0.1. The probability of the superposition of the prints of two different droplets is fairly small in this case. For a liquid flow rate of 3 l/min, mean droplet radius 25μ , and width of 4-mm aperture the required speed of the tube 5 is 0.2–0.4 m/sec.

The method of determining the size of droplets from the size of the prints formed on a surface coated with a layer of soot or magnesium oxide is well known and is often used. According to the results of experiments, for a layer of soot three times as thick as the radius of the droplet of liquid, irrespective of its physical and chemical properties, and a droplet speed of 5 m/sec or more for droplets of radius more than 10μ the ratio of the radius r_d of the print to the droplet radius r is, according to [4], ~ 1.0 or, according to [5], ~ 1.20 . We took the value $r_d/r = 1.1$.

As a standard atomizer we used an AG-L6 agricultural aerosol generator with an angled nozzle [6]. The liquid (water-glycerol mixture containing 60% glycerol) was fed by gravity into the narrow section of the Venturi tube through a discharge nozzle and was atomized by a rapid stream of air driven through the nozzle by an air blower powered by a gasoline motor. The diameter of the outlet section of the nozzle was 80 mm and the air speed in this section was 27 m/sec.

The second method of determining the droplet size distribution involved deposition of the droplets in a closed room [7]. For this purpose we used a concrete storeroom with dimensions $11 \times 11 \times 3.5$ m. An automobile with an operating AG-L6 generator was driven at a speed of 9 km/hr past the slightly open door of the storeroom. From the nozzle of the generator, which was pointed horizontally in the direction of the door, a relatively small number of droplets entered the room and were deposited on the floor. At 100 points on the floor glass plates coated with a fine layer of silicone were placed [8]. After the experiment the plates were examined under the microscope and the size distribution of the deposited droplets was determined (with due regard to the area of the floor covered by each plate) and assumed to be equivalent to the size distribution of the droplets produced by the atomizer.

In the third method [7] the droplet size distribution was determined from the deposits of a wave aerosol in field conditions in a very light wind (~ 0.2 m/sec) and stable state of the bottom layer of the atmosphere (inversion). An AG-L6 generator mounted on a truck moving along the edge of the experimental area (500×500 m) approximately perpendicular to the direction of the wind produced a wave of aerosol, which was car-

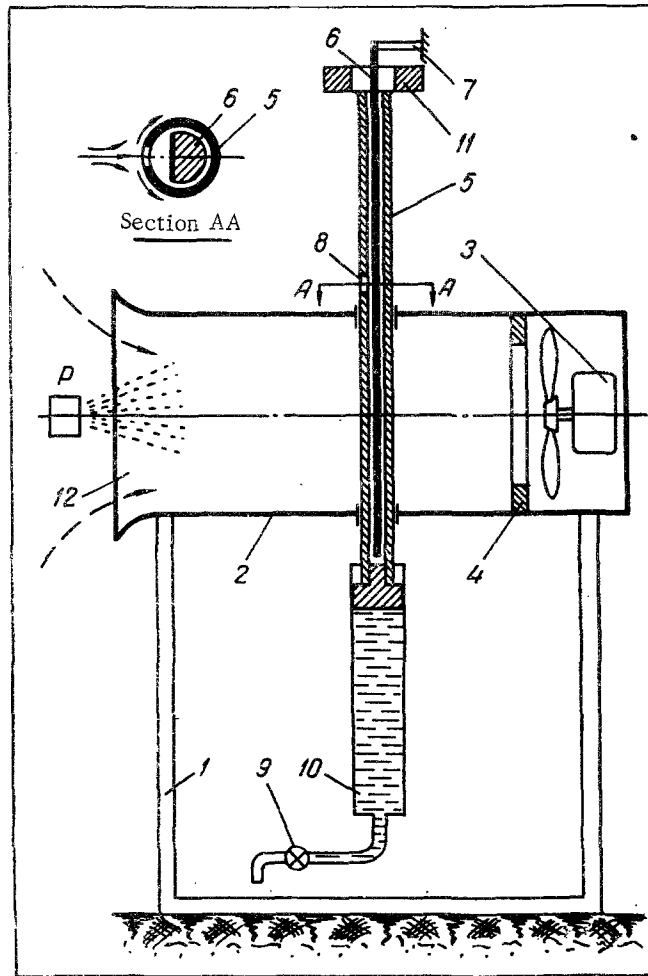

Fig. 1. Diagram of stand for atomizer tests.

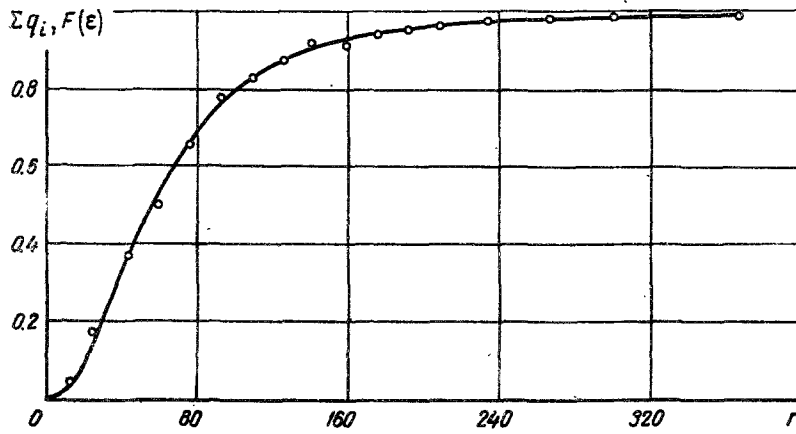

Fig. 2. Comparison of theoretical and empirical distributions. Experiment No. 8.

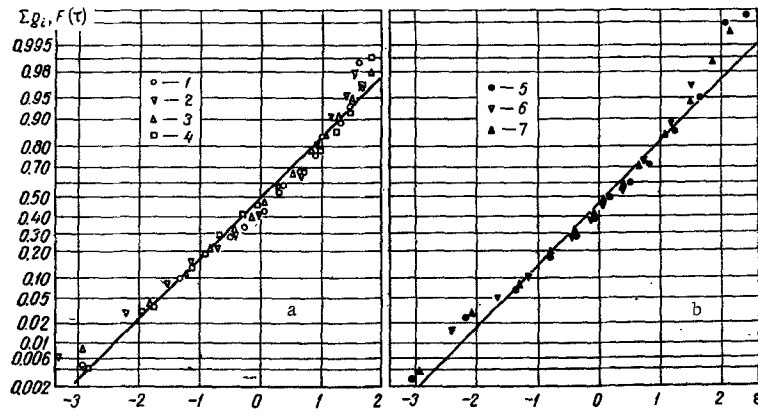

Fig. 3. Comparison of theoretical and empirical distributions. Experiments 1-4 (a) and 5-7 (b). The numbers of the points correspond to the numbers of the experiments.

ried by the wind onto the area. The nozzle was horizontal, perpendicular to the motion of the car, in the direction of the wind and was 1.6 m above the ground. The area had 209 control points, each with a glass plate coated with silicone. (Such a large number of control points is required to smooth out the fluctuations of the depositions of aerosol [9]). After the experiment the plates were examined under the microscope in the same way as in the second method.

We conducted eight experiments altogether: four (Nos. 1-4) by the stand method, three (Nos. 5-7) by the method of deposition in a closed room, and one (No. 8) by the field method. The experimental conditions are indicated in Table 1.

The table shows that in experiments on the stand the barometric pressure was a little higher than in the other experiments and the air and liquid temperatures were a little lower. These differences partially compensated one another from the viewpoint of the quality of the spraying. The other conditions were practically the same. In the second and third methods the number of measured droplets was much greater than in the first method.

The experimental results—empirical distributions of the weight of sprayed liquid as regards droplet size—are given in Table 2. This table shows that in the field experiment (No. 8) we obtained a "tail" of large droplets with radius of 250 to 416 μ , which, however, made up only a small fraction of the weight of the liquid (about 1%). In experiments Nos. 5-7 (in the room) the largest droplets found had a radius of 250 μ , while in the stand experiments they were only 150 μ . In all the experiments, however, the weight fraction of the liquid contained in droplets of radius more than 150 μ was small (not more than 9%), i. e., the observed differences from the quantitative viewpoint are of minor significance.

A quantitative comparison of the obtained empirical distributions would be greatly simplified if we knew of some theoretical law describing it, even approximately. This question is of great independent interest.

We assumed that when the liquid is finely divided by the fast air flow in the nozzle of the AG-L6 generator

the size distribution of the formed droplets is described approximately by a logarithmic normal law, i. e., that the density of distribution of the weight of the liquid as regards logarithm of the droplet radius is

$$G(\lg r) = \frac{1}{\lg \delta \sqrt{2\pi}} \exp \left[-\frac{(\lg r - \lg r_m)^2}{2(\lg \delta)^2} \right]$$

or

$$F(\varepsilon) = \int_{-\infty}^{\varepsilon} G(t) dt = \frac{1}{2} \left[1 + \frac{2}{\sqrt{2\pi}} \int_0^{\varepsilon} \exp(-t^2/2) dt \right] = \frac{1}{2} [1 + \Phi(\varepsilon)],$$

where

$$\lg \delta = \sqrt{(\lg r - \lg r_m)^2}, \\ \varepsilon = (\lg r - \lg r_m) / \lg \delta.$$

To test this hypothesis we compared the experimentally obtained empirical distributions with the corresponding logarithmic normal distributions. Figure 2 shows the corresponding graph for experiment No. 8. The points show the empirical integral distribution $\Sigma g_i = f(r_{i_{\max}})$, while the continuous line shows the logarithmic normal distribution $F(\varepsilon) = f(r)$. In both distributions the weight median radius of the droplets $r_m = 55.1 \mu$, and the logarithm of the standard geometric deviation is $\log \delta = 0.314$.

The graph shows a perfectly satisfactory agreement between the empirical and theoretical distributions.

Figure 3 shows the corresponding graphs for experiments Nos. 1-4 and 5-7. To exclude the effect of differences in r_m these graphs are presented in dimensionless form. The agreement between the empirical and theoretical distributions is again quite satisfactory, i. e., our hypotheses can be regarded as confirmed.

In view of this we can present the results of each experiment by the corresponding values of the two parameters which determine the logarithmic normal distribution: the weight median droplet radius r_m and the logarithm of the standard geometric deviation $\log \delta$.

The values of these parameters for each of the experiments are

No. of experiment	1	2	3	4
r_m, μ	50.5	46.9	52.3	42.7
$\lg \delta$	0.292	0.282	0.263	0.279
No. of experiment	5	6	7	8
r_m, μ	50.1	66.1	52.4	55.1
$\lg \delta$	0.276	0.294	0.296	0.314

Unfortunately, experiment No. 8 was the only one conducted by the field method and, hence, can be used only for qualitative comparisons; however, the results of experiments Nos. 1-4 (stand method) and 5-7 (measurements in a closed room) can be compared statistically, by the analysis of variance, for instance ([10], p. 40).

Treatment of the data by this method showed that differences in the values r_m and $\log \delta$, obtained in the experiments Nos. 1-4, on one hand, and 5-7, on the other, are statistically insignificant, i. e., these differences lie within the limits of accuracy of the measurements.

The fact that measurements of the same object by fundamentally different methods gave statistically identical results indicates that each of these methods and, hence, the stand method gives correct results.

This also indicates that the over-all systematic effect of the distorting factors (effect of fast shutter, etc.) is small in comparison with the chance errors in each of the tested methods.

A statistical analysis of the data by the small-sample method ([10], p. 297) showed that when the droplet size distribution was determined three times on the stand the error in determining r_m did not exceed $\pm 20\%$ at the 90% level of significance. In the case of two measurements the error was excessively large. The measurements had to be repeated at least three times. The values of $\log \delta$ have a smaller error than the values of r_m . According to the results of an analysis by the small-sample method, the accuracy of the stand measurements is greater than in the case of the much more laborious measurements in a closed room. Moreover, the latter method can be used only with nonvolatile liquids.

In view of the results obtained we can recommend the devised stand method for practical application.

NOTATION

$u_i(R)$ is the speed of droplets of i -th class at distance R from tunnel axis in front of collecting rod; u_d

is the air speed in tunnel; N_i is the number of droplets of i -th class produced by atomizer in time τ ; r is the droplet radius; r_d is the radius of print of the droplet; $r_i, r_{i\max}, r_{i\min}$ are the mean, maximum, and minimum radii of droplets of i -th class; r_m is the weight median radius of droplets; R_0 is the radius of tunnel; $c_i(R)$ is the volume concentration of droplets of i -th class at distance R from the tunnel axis in front of collecting rod; $n_i(R)$ is the surface concentration of deposited droplets of i -th class on the working surface of the rod at distance R from the tunnel axis; g_i is the relative weight of droplets of i -th class; $\alpha_i = f(\text{Stk}_i)$ is the capture factor for droplets of radius r_i flowing around the tube; $\text{Stk}_i = 2\rho_L u_d r_i^2 / 9\eta D$; ρ_L, η_L, σ are the density, viscosity, and surface tension of the liquid; η is the viscosity of the air; D is the diameter of the stand tube; $\Phi(\epsilon)$ is the probability integral; δ is the standard geometrical deviation; F is the integral function of distribution of weight of liquid as regards the logarithm of droplet radius.

REFERENCES

1. L. M. Levin, Physical Investigations of Coarsely Dispersed Aerosols [in Russian], Izd. AN SSSR, 1961.
2. N. A. Fuks, Mechanics of Aerosols [in Russian], Izd. AN SSSR, 1955.
3. V. F. Dunsii and N. V. Nikitin, IFZh [Journal of Engineering Physics], 9, 54, 1965.
4. G. D. Salamandra and I. M. Nabokov, ZhTF, 27, 614, 1957.
5. K. R. May, Journal of Scientific Instruments, 27, 128, 1950.
6. V. F. Dunsii, collection: Aerosols and Their Application, ed. A. G. Amelin [in Russian], Izd. MSKh SSSR, Moscow, 1959.
7. V. F. Dunsii, I. F. Evdokimov, V. M. Krasil'nikov, K. P. Mikulin, and Z. M. Yuzhnyi, Tr. GGO im. A. I. Voeikova, no. 172, Gidrometeoizdat, Leningrad, 1965.
8. Z. M. Yuzhnyi, Kolloidnyi zhurnal, 20, 509, 1958.
9. V. F. Dunsii and S. A. Evseeva, Izv. AN SSSR Fizika atmosfery i okeana, 1, 501, 1965.
10. A. M. Dlin, Mathematical Statistics in Engineering [in Russian], Moscow, 1958.

16 August 1966

Institute of Phytopathology,
Moscow